

Oakley Sound Systems

Compact Power Supply

PCB Issue 1

User Manual

V1.0.01

Tony Allgood B.Eng PGCE
Oakley Sound Systems
CARLISLE
United Kingdom

Introduction

This is the User Manual for issue 1 of the Compact PSU circuit board from Oakley Sound. The Compact PSU is a small footprint power supply unit with onboard regulators, heatsinks, fuses and power distribution for Oakley and MOTM synthesisers. Current capacity depends on the source of AC power that the unit runs from, but it has the potential to supply up to 750mA on each power rail.

As well as giving details as to what the Compact PSU board does, this document contains instructions on how to wire up your board to your source of power, any external switches and the optional power indicators. We will also look at the Oakley power buss and how it differs from the MOTM one yet retains complete compatibility with it. I will also give you some information about suitable sources for your low voltage AC power supply.

The Oakley Compact PSU allows for various options in the installation. You can use the unit either in full wave rectification mode for connection to tapped lineumps or twin secondaries, or in half wave rectification for single phase AC output wallwarts and lineumps. If all this sounds very confusing at the moment, do not worry, in this manual I will try to make it clearer so that you make the right decision about what power supply you will need.

If you are building the Compact PSU as a complete DIY project please also download the latest Builder's Guide. This can be found on the Compact PSU webpage along with our very useful generic parts and construction guides.

Safety Warning

This supply has been designed to work with isolated low voltage AC inputs only. Connection to any other supply is done at your own risk. Low voltage is classified as being less than 25V with respect to the ground potential. Voltages above this level can, and often are, lethal to living creatures.

Oakley Sound Systems will not advise on building or modifying this board to allow for direct connection to the mains, or other high voltage sources, further to what is provided in this document. Please do not ask us for additional information pertaining to direct mains connections or using internally mounted transformers as we will not give it.

For safety and legal reasons we cannot recommend powering this board from any other supply than low voltage AC output mains adapters.

Oakley Sound Systems are not liable for any damages caused by the misuse of this product. It is your responsibility to use this product safely. If you have any doubt about installing a safe power supply, then please do not attempt to do so.

The Oakley Compact PSU module

The power supply board will allow the conversion of a suitable low voltage alternating current (AC) to be rectified, smoothed and regulated for operation with the Oakley Modular. The module contains both the regulating devices, their heatsinks to keep them cool, and up to seven 0.156" MTA headers for easy connection to your Oakley and other MOTM compatible modules.

The voltage output of the module is a split rail 15V supply. This means it generates both +15V and -15V. That is, two power rails, one of a positive voltage, the other a negative one. These voltages are measured with respect to a common ground which is normally connected, via your house's wiring, to the earth that you stand on. The voltage across both rails is 30V, with the common ground sitting exactly in the middle of this at 0V.

The output current capability is the maximum current you can draw out of the power supply. The current taken from the supply is determined by the amount of modules you are connecting to the power supply. If you are using a 500mA (or 0.5A) AC wallwart* then the most current you can take from this power supply module is 250mA from each rail. To be on the safe side it is best probably to limit this to 200mA per rail. That is, take no more than 200mA from either the +15V supply or the -15V supply.

Most Oakley modules take around 30mA each from both the +15V and the -15V rails. That means you should restrict yourself to driving a maximum of six synthesiser modules in your system. However, you must remember that some modules will take a lot more than 30mA, while some take a lot less. Check with the module's User Manual or webpage to see how much current each one takes.

Various companies make linelumps** with a greater capacity than 500mA. If you can get a 1A output one than this will be able to drive up to 500mA per rail, although again, you should probably think of this as being safer to take no more than 450mA per rail.

Some linelumps, like the Yamaha one mentioned later on, use a split AC output or a centre tapped AC output. This means it has three wires coming from it and will use a different plug from the usual round barrel one you see on the single phase AC wallwarts. Single phase mains adapters have only two wires coming from them so they can use a simpler connecting plug.

The Oakley Compact PSU can be built with an optional full wave rectification ability. This allows it to utilise split AC outputs very effectively. The recommended Yamaha supply can drive up to 0.94A and, when used with the full wave rectification option, the Compact PSU module can supply up to 0.9A to both the +15V **and** the -15V rails.

Two sets of screw terminal blocks are provided for connecting the low voltage AC power source to the board and the optional power switch. If you are using a single phase wallwart to power the PSU module than you need only to use two terminals per terminal block.

The board has four mounting holes for stable placement onto your modular case. Care should be taken so that the board's various board mounted components do not come into contact with any part of your modular's enclosure. One of the holes, the bottom right hand one, is

connected to the ground pins of the MTA headers via a resistor, R8. We will look into this later on in the document but unless you are fitting a mains powered transformer into your modular housing you will have no need for R8 or an earthing point.

The power supply has two integral fuse holders in case of a problem with the power supply circuitry itself. Two fuses are needed if you are using full wave rectification, but only one, F2, is required for ordinary half wave rectification. The fuse type should be a slow blow or anti-surge type. The size is 20mm. It should be rated at between one and two times the maximum current of your wallwart. Thus a 500mA AC output mains adapter should have a fuse that is rated between 500mA and 1A, ideally 750mA. A 1A linelump should have a fuse that is between 1A and 2A, ideally 1.5A.

Three on-board LEDs, one for +15V, one for -15V and one for the AC input, provide a quick visual reference that all is well. All three LEDs could be fitted externally to the board and be mounted on a front panel. However, the recommended way is to mount only the AC indicator on the front of the synthesiser along with the AC power standby switch.

As we have seen the standard circuit provides two outputs, one at +15V and one at -15V. Both output voltages can be finely adjusted with one trimmer. However, the unit can be very easily modified to supply +/-12V if the need arises.

* A wallwart is the vernacular term for a low voltage mains adapter that plugs directly into the wall. These take the form of a black plastic block that is shaped like an oversized mains plug. Its called a wart simply because its appearance is somewhat uglier than a normal slimline plug.

** A linelump does the same job as a wallwart but it generally can handle greater currents. Because of its increased size it cannot be made so that it will safely fit into a plug socket directly. Thus the adapter sits in a black plastic box and connects to the wall via a cable and traditional mains plug. It is therefore a black plastic lump connected to a line.

The Power Supply to the Power Supply

The standard method of powering the unit is from a low voltage tapped AC source. The safest available option is to use a ready made 'wallwart' or 'line lump' supply.

You can use any 15V or 18V AC output wallwart of line lump you can source. The current capability of the mains adapter, sometimes incorrectly called the 'ampage' will determine the maximum current draw of your Compact PSU.

In the UK, the following types are recommended and have been tested to work with the Compact PSU:

Maplin N57AT

This is a 500mA single phase AC output wallwart. It is a variable output type. This means it has a little selector switch on the underside of the unit that allows you to change the output voltage. You can select either 15V or 12V. Either voltage setting seems to produce enough voltage for the Compact PSU to deliver +/-15V up to 200mA.

Because this is a single phase unit the compact PSU is wired in half-wave rectification mode. You notice that only two wires come out of the wallwart and that you can select from a variety of output socket types. Simply chose the one you would like to use on your system and buy the appropriate socket for it to go into. I tend to recommend the 2.5mm DC power plug one since this is the most common type of power socket.

You should fit fuse F2 only and it should be an anti-surge type and rated between 500mA and 1A.

Yamaha PA-20

This is a line lump supply and features a fixed 17.5-0-17.5 volt AC output at 0.94A maximum. This means it gives us two AC outputs with a centre tap or mid point reference voltage. So unlike the single phase AC adapter output with two leads, this one has three. This means you need to use the Compact PSU in full wave rectification mode.

The PA-20 is made for Yamaha products and they are available from Yamaha spares departments. You should ask for the power pack that goes with the MG12/4 mixer. These are CE approved and connect to the mains via your local mains connector. They will be different types depending on the country you need them for. It comes with a handy three way plug at the low voltage end that you can use with an appropriate socket. If you wish you can ditch their connector and use your own. Maplin sell a suitable three way connector to fit the Yamaha one perfectly. Their part number is FM51F.

In the UK the line lump's part number is V9812300 and the total cost is around £30 including VAT and postage. We do have permission from Yamaha-Kemble in the UK to use this particular part for the Oakley system, but in other countries this may be not so clear cut. The liability issue once again rears its ugly head and they may not want to sell power items for

third party use. The best thing is to do is just to ask for a spare supply for your own MG12/4 mixer.

The Yamaha supply can deliver up to 0.94A. However, I have tested the Compact PSU whilst drawing 0.9A from both the +15V and -15V rails and the two heatsinks get very hot. So although it is quite capable of driving this sort of current for a short period of time I would recommend that the current taken when using the Yamaha PA-20 should not generally exceed 750mA.

You should fit both fuses and both should be anti-surge types and rated between 1A and 2A.

The following devices have not yet been tested but should work:

Maplin N58AT

This is a 1A single phase unit. It has the potential to deliver up to 400mA per rail when the Compact PSU is used in half wave rectification mode.

If you have successfully used the Oakley PSU with any other types of power pack please do let me know either directly or via the Oakley Sound forum at www.muffwiggler.com

Wiring Diagrams

Input wiring will depend on the type of wallwart or linelump you will be using.

Standard AC output wallwart

Single phase, two wire, wallwarts or linelumps need to use half wave rectification so the Compact PSU can generate both positive and negative supplies simultaneously. They only need the terminal's AC2 and 0V2 wired to the power socket. AC1 and 0V1 are left unused

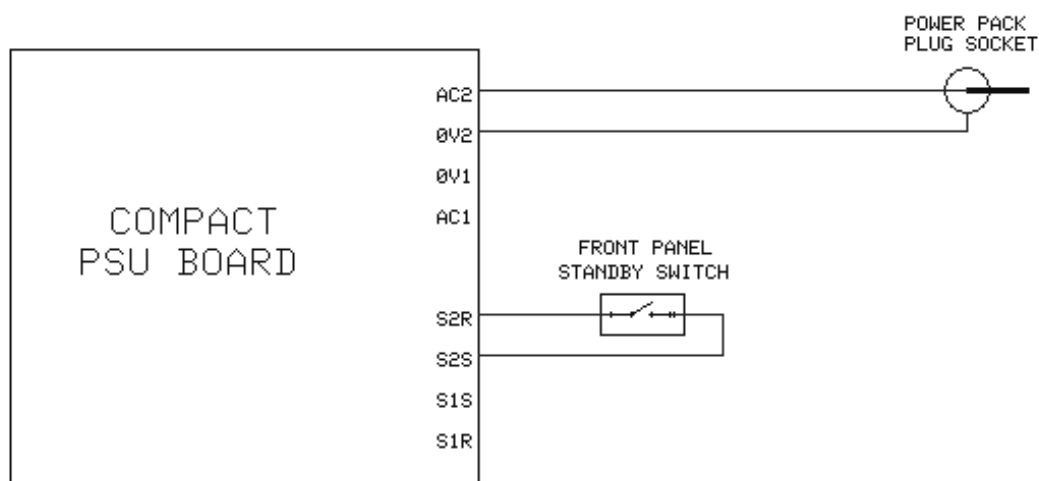

Wallwart with single phase AC output, eg. Maplin N57AT

The front panel switch is a single pole single throw (SPST) switch which simply connects S2R and S2S together when switched on. You can replace the switch with a simple wire link, but I do recommend that a switch be fitted so the socket doesn't have to take the full surge current when you insert it with the wallwart powered up.

I also recommend fitting the AC indicator LED too. This is so you know the wallwart or linelump is on. The AC indicator is designed to indicate the status of incoming power and is not determined by the position of the standby switch.

The standby switch should not be used to turn the unit off permanently. This should be done by either switching the adapter off at the mains socket, or by pulling the adapter's plug out of the mains socket.

Centre tapped wallwarts and linelumps

Centre tapped linelumps will have three wires coming from their connector. It will have two AC outputs and one 0V. Take one of the AC outputs to terminal AC1 and the other AC output to terminal AC2. It should not matter which AC output goes to AC1 or AC2. The 0V should go to the 0V2 terminal.

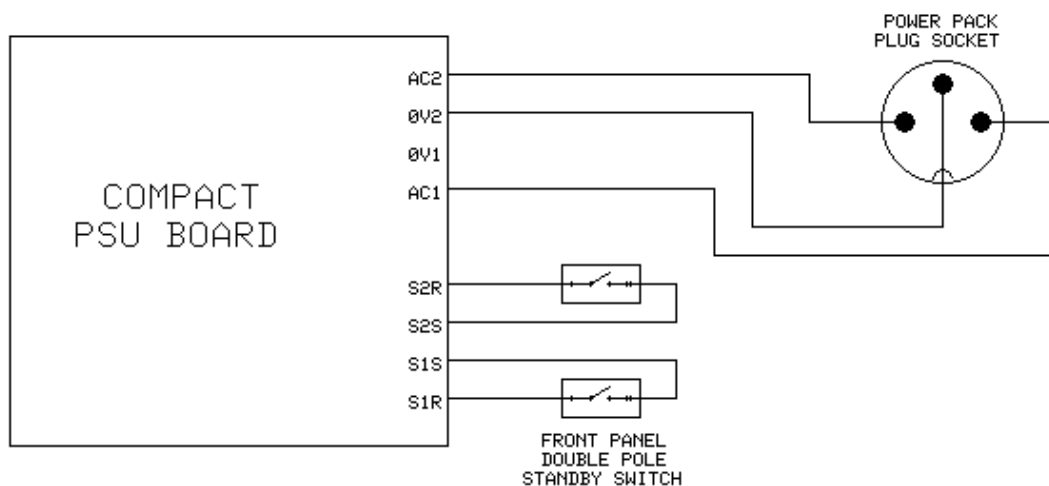

Figure 2. Linelump wiring with centre tapped output, eg. Yamaha PA-20

The front panel switch is a double pole single throw (DPST) switch which connects S2R and S2S together, and S1R and S1S together, when switched on. You can replace the switch with two wire links, but I do recommend that a switch be fitted so the socket doesn't have to take the full surge current when you insert it if the linelump is powered up.

I also recommend fitting the AC indicator LED too. This is so you know the linelump is on. The AC indicator is designed to indicate the status of incoming power and is not determined by the position of the standby switch.

The standby switch should not be used to turn the unit off permanently. This should be done by either switching the adapter off at the mains socket, or by pulling the adapter's plug out of the mains socket.

Fitting an Internal Mains transformer

Be afraid, be very afraid...

Some of you old hands will laugh about the level of hysteria that surrounds direct mains connection to DIY projects. However, this fear is more to do with our litigious society than the real danger to the builder. Even so, I have had more than my fair share of high voltage shocks over the years and it is not something I would want any builder to have to experience. It has been purely luck that has saved me in several of those cases.

So I will say again – do not attempt to build a mains transformer into your modular case, or any other project, without realising that to do so carries a risk of death to either you, or to the person who may inadvertently put their fingers into your half built construction. Furthermore, it is up to you as the builder of such an item to make sure, that once built, the item is safe to use and meets all current safety legislation.

This is not a complete set of instructions on how to fit a transformer into a piece of electronic equipment. This information is offered only as a guide and should not be considered as your only source of information. No further information will be provided by myself or Paul Darlow regarding the construction of mains powered items.

The mains transformer's secondaries should be rated:

18-0, 18-0 (or 18-0-18)

50VA

This will give you a power supply that should be theoretically capable of 1A each rail. However, due to heatsink size I would recommend that no more than 750mA be taken from each rail. Taking any more than this will result in very hot heatsinks and possible damage to the semiconductor devices. So if you do want to take more than this you should consider either mounting the semiconductor devices on external heatsinks or using our other more powerful power supply design.

Higher secondary voltages can be tolerated although you need to consider three things:

1. You may need a physically larger transformer for the same output power.
2. Your smoothing capacitors should be rated at a high enough working voltage to handle the increased voltage across them.
3. The heatsinks will need to dissipate more energy because of the greater voltage drop across the regulators.

In the wiring diagram I have included a suggested wiring method for connecting up a mains transformer. Not all mains transformers are the same, some have additional windings, others have tapped windings. I have simply used a single primary, double secondary type for example only.

For the mains fuse you should use a 500mA anti-surge type. All wiring at mains potential should be adequately insulated and protected from straying fingers.

There is no need to fit an AC standby switch since you will be fitting a proper mains power on switch in series with the transformer primary coil. However, you will need to link S1A to S1R, and S2S to S2S.

You will want to tie the ground lines, pins 2 and 3, of the MTA headers to earth potential somewhere in your system. The Compact PSU board provides a convenient location to do this via the EARTH pad and R8.

It is good practice with everything you build, that has both live mains inside and a metal case or panels, to fit a safety earth. UK legislation says that any metal panelling should be adequately insulated, ie. double insulated, or connected to earth.

Remember that my own recommendation is not to use a internal mains power supply, period. However, if you do, I recommend that you make sure any metal casing and front panels are earthed inside your modular. This would mean that R8 is a wire link and that the earth pad is connected with wire to the earth tag on the IEC mains power connector. This joins the two 0V lines on the headers to the mains earth directly.

It is possible that by earthing the front panel you may introduce earth loops when you connect your mixer to the sockets of one of the modules. The outcome of this is audible humming at 50/60Hz and its harmonics. It is produced by earth currents travelling down the screen of the connecting cable(s). This can be avoided by careful studio wiring and/or by using balanced audio lines to pipe signals to and from the modular and mixing desk. Most mixing desks will have balanced outputs and inputs.

If you can **guarantee** there is no way that mains live or neutral can ever touch the metal casing or any front panels then you may be safe to use R8 as a 100R 1W metal film resistor. You will still need to connect the earth pad to earth though. This way you can use single ended audio cables back to your desk as adverse earth loops cannot form. The resistor 'gently' ties the modular's ground to earth potential. The 'safety' earth will then be applied to your modular via the connecting leads, although these cannot and must not be relied upon in the event of a failure.

It should be noted that the bottom right mounting hole is also connected to the EARTH pad. Since the mounting holes are actually big solder pads this means that any metal nut and bolt that screws into this particular hole will also be connected to the earth pad.

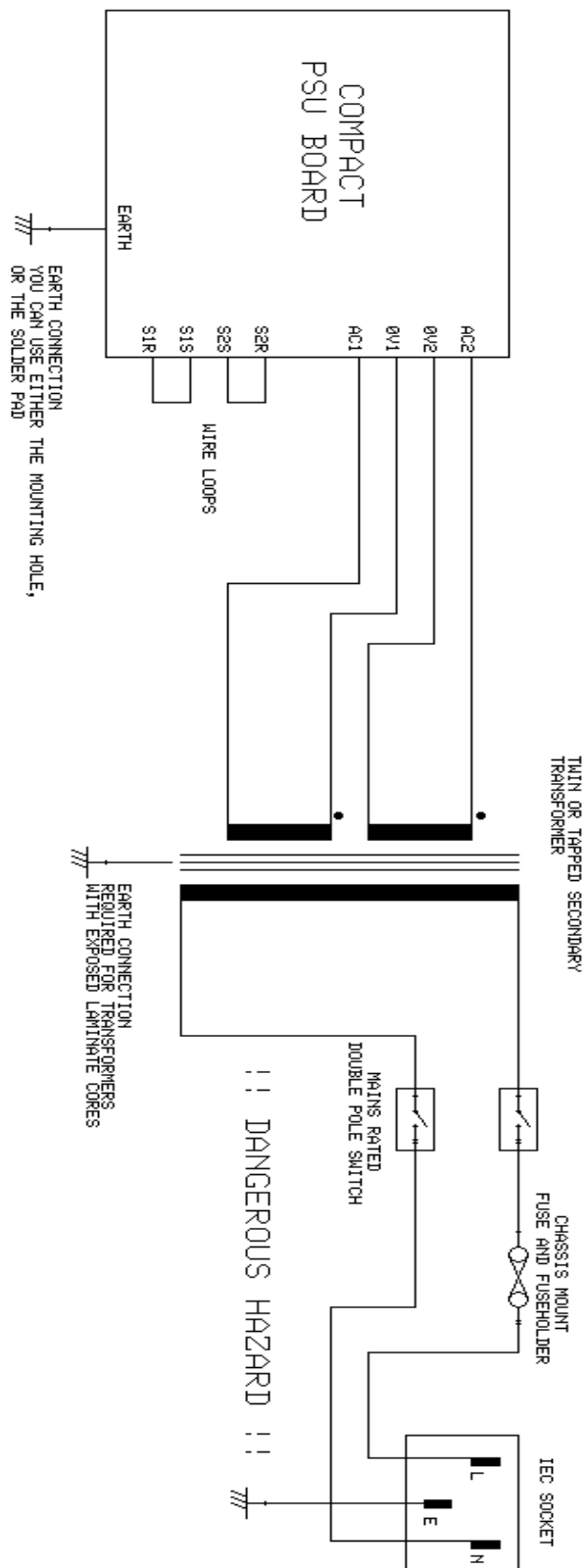

Mains wiring diagram. For experienced builders only!

The Oakley Power Bus

In an ideal world I wanted the Oakley power bus to be based on a five way 0.156" MTA or Molex connector. This would contain +15V, -15V and three grounds. One ground would be the safety ground; this would be connected to the front panels and then directly onto the main's supply earth. The second would be a clean ground for all the analogue modules to take their supply reference, the zero volt line, ie. 0V. The third would be a dirty ground. This would be the ground reference for things like the noisy digital circuitry and LED switching. However, this system would be incompatible with the MOTM modular which has a four way connector for its analogue modules. So the question now remained, how could I make my system work with MOTM, yet still retain some of the features I needed.

The chosen Oakley power bus comprises of +15V and -15V lines with two grounds. These grounds are not connected together as in the MOTM. They are joined only at the power supply in a wholly Oakley Modular.

In an Oakley modular one of the grounds, pin 2, goes straight to the power supply's star point. This is the analogue reference point and is correctly called 0V or module ground. This is the same as the MOTM ground. The second ground is on pin 3. This is also connected to the power supply's ground. But this ground is connected only to the metal lugs of the sockets on each module and nothing else on the module. It is this connection that sets the potential of the patch lead's screening and the metal case of the modular. This way it is impossible for ground currents to travel down the inserted patch cords, since the panel is isolated from the system ground except at one point.

However, this only works if ALL your modules follow this rule. If you insert just one MOTM module into this system, the 'benefits' are lost. MOTM modules can be modified to allow full Oakley compatibility although this should be done as you are building the module. Modifying a completed MOTM module is possible, but the reverse side of the PCB must be accessed so that you can cut the required tracks.

But I said earlier that the MOTM and Oakley power systems were compatible. And indeed they are. Any Oakley module will work in a MOTM system. And vice versa. But you will not get the inherent advantages of a two ground system if you mix and match systems.

Having said all that I have yet to hear any problems related to ground currents in any MOTM or MOTM/Oakley systems.

One last thing, the LK link on the Compact PSU board joins the pin 2 ground with the pin 3 ground. By omitting LK you essentially isolate the pin 3 from the ordinary ground. There is little reason for doing this in your modular, but I added it to allow anyone the option of using the now floating pin 3 rail for something else.

Final Comments

I hope you that the Oakley Compact PSU lives up to your expectations and provides you with a reliable source of power for your modular system.

If you have any questions about the module, an excellent source of support is the Oakley Sound Forum at Muffwiggler.com. Paul Darlow and I are on this group, as well as many other users and builders of Oakley modules.

If you have a comment about this user manual, or have a found a mistake in it, then please do let me know.

Last but not least, can I say a big thank you to all of you who have helped and inspired me over the years. Thanks especially to all those nice people on the Synth-diy, Oakley-Synths and Analogue Heaven mailing lists.

Tony Allgood at Oakley Sound

Cumbria, UK

© September 2009